

Ice Cuber 80kg/24h with 40kg bin - Water-cooled

ITEM # _____

MODEL # _____

NAME # _____

SIS # _____

AIA # _____



730546 (FGC85W)

Ice maker, cube, 80kg/24h, self-contained, 40kg ice collection bin included, water-cooled (ice cube: 18gr) (R452a)

Short Form Specification

Item No. _____

AISI 304 stainless steel exterior. Food grade ABS interior. Stainless steel spray arms removable without the use of tools. Fully automatic in operation. Efficient water cooling system. Suitable for gravity drain only. Flexible water supply and drain hoses. A spray system produces solid, crystal clear ice cubes.

Rated output is at an ambient air temperature of 21°C and water supply temperature of 15°C.

Self-contained storage bin capacity: 40 Kg.

Main Features

- Compact dimensions of the ice cubers make them highly suitable for any location, particularly those where space is at a premium.
- Water consumption and productivity calculated using 15°C water temperature and 21°C ambient temperature.
- Model available in water-cooled version.
- The ice-making method (spray layering) guarantees crystalline, compact, hygienically pure ice cubes that are resistant to melting.
- Ice cube cone shape with the trunk sides slightly squashed.
- Bin integrated as standard.
- Compliant to CE requirements for safety.
- Fully automatic in operation.
- Operates over a wide range of temperatures.
- Suitable for gravity drain only.
- Rated output is at an ambient air temperature of 21°C and water supply temperature of 15°C.

Construction

- Reliability guaranteed by the quality of the construction materials used (plastic flap on the front, top and sides in 304 AISI stainless steel) and the sophisticated product and process technology involved.
- The sprayers are easy to take away, permit a simple flowing and prevent limestone formation.
- Internal ice cubes container in ABS.
- Plug as standard (schuko type).
- AISI 304 stainless steel exterior.
- Stainless steel spray arms removable without the use of tools.
- Adjustable feet 110-150 mm.
- Environmentally friendly: R452a as refrigerant gas.

APPROVAL: _____

Side

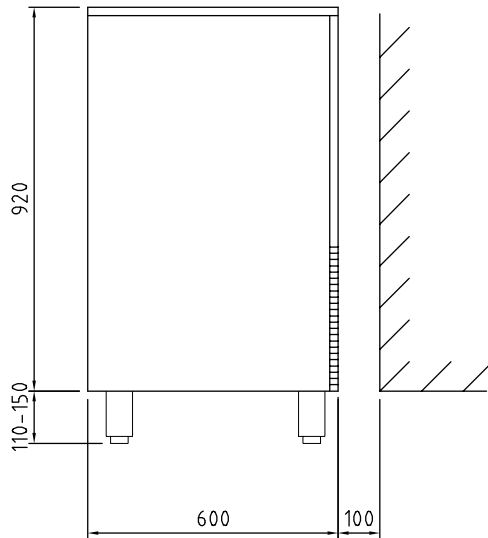

Top

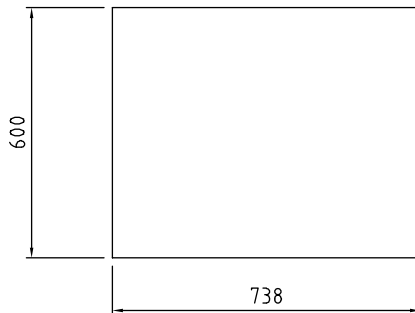

- CW11** = Cold Water inlet 1 (cleaning)
- D** = Drain
- EI** = Electrical inlet (power)

Front

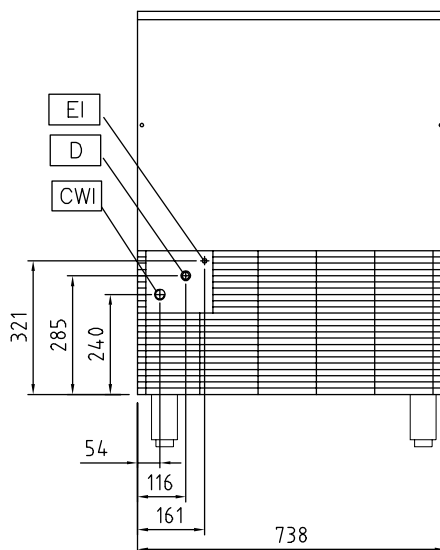

Electric

Supply voltage:	730546 (FGC85W)	220-240 V/1N ph/50 Hz
Electrical power max.:		0.8 kW

Capacity:

Bin capacity:	40 kg
---------------	-------

Key Information:

External dimensions, Width:	738 mm
External dimensions, Depth:	600 mm
External dimensions, Height:	1030 mm
Net weight:	86 kg
Output:	80 kg/day
Kind of cube:	Ice Cube 18 g

Sustainability

Noise level:	57,8 dBA
Refrigerant type:	R452A